



RoHS Compliant
Directive
2002/95/EC

Contents





1	Introduction	2
2	Applications	2
3	Key Features	2
4	Technical Specification.....	2
5	CE Marking.....	2
6	Dimensions & Installation.....	3
7	Wiring & Connection Diagram	3
8	Safety Advice	4
9	Installation	4
10	Commissioning	4



UNITED AUTOMATION LTD

Southport Business Park
Wight Moss Way
Southport, PR8 4HQ
ENGLAND

Tel: 0044 (0) 1704 – 516500
enquiries@united-automation.com
www.united-automation.com

    unitedautomationltd  UA_Limited



1 Key Features

- Simple Wall Mounting
- IP55 protection for outdoor installation
- Soft-Start function
- Simple In-Line wiring, via 3-core cables
- Pre-selected heat output levels for optimum comfort control
- Power output indication
- Integral EMC filter suppression
- Relay override at maximum output - minimizing heat dissipation

2 Applications

Typical applications are Pub Patio areas, Smoking Shelters, Restaurants, Warehouses, Work shops.

3 Technical Specification

Supply Voltage	230V AC +/-10%
Supply Frequency	50Hz
Load Rating (maximum)	6.5A (1.5kW @ 230V AC & 25°C ambient)
Output Levels (total of 5 levels)	Off, Low, Medium, High & Full Power
Fusing or MCB Rating (external)	13A (Brown) Mains fuse or 16A domestic MCB
IP Rating	IP55 – Dust protection; protected against water jets
Operating Temperature	-20°C to 50°C
Maximum Ambient Temperature	30°C
Fixings	4 x 3.5Ø holes (on 97 x 82mm centres)
Supply & Load Cable (recommended)	1.0mm ² 400V AC (minimum rating)
Terminal Cable Ratings	2.5mm ²
Terminal Torque Settings (maximum)	0.5 Nm
Weight	500g
Power Consumption (maximum)	70mA
Isolation Voltage	2500V RMS

4 Introduction

The INFRESCO-VR-1.5kW controller offers variable control of mains-driven loads, specifically Quartz Halogen Infrared heat lamps, rated up to a total of 1.5kW.

This microcontroller-based unit incorporates a 'soft-start' gradual switch on function to eliminate the lamp's initial high inrush current – potentially increasing the lamp life by as much as 30%.

Output levels are selected by up & down push-buttons with a high-intensity LED indicating when the controller is regulating the power to the lamp load.

A relay override function is built in the circuit design – thus, at maximum power (100%), the relay 'switches in' and bypasses the power (triac) and suppression (choke) devices. This helps to keep the units heatsink temperature to a lower operating temperature, since they are not in use in this state and generate no heat. Normal control is resumed below approximately 96% of the power setting.

Installation is simple and once installed is very low maintenance.

5 CE Marking





This unit carries a 'CE' mark and incorporates a filter (complies to BS EN55022 Class B) to comply with the EMC directive. For further details see the Product Declaration of Conformity (DofC).



UNITED AUTOMATION LTD

Southport Business Park
 Wight Moss Way
 Southport, PR8 4HQ
 ENGLAND

Tel: 0044 (0) 1704 – 516500
 enquiries@united-automation.com
 www.united-automation.com

   unitedautomationltd  UA_Limited



6 Dimensions & Installation

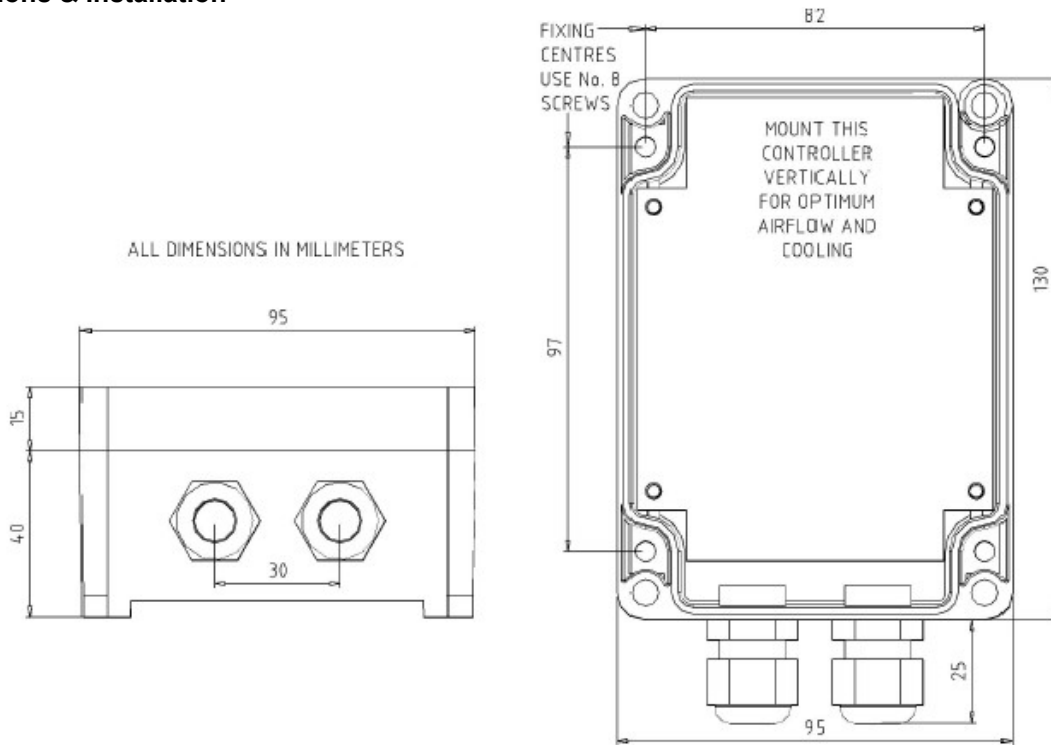

7 Wiring & Connection Diagram

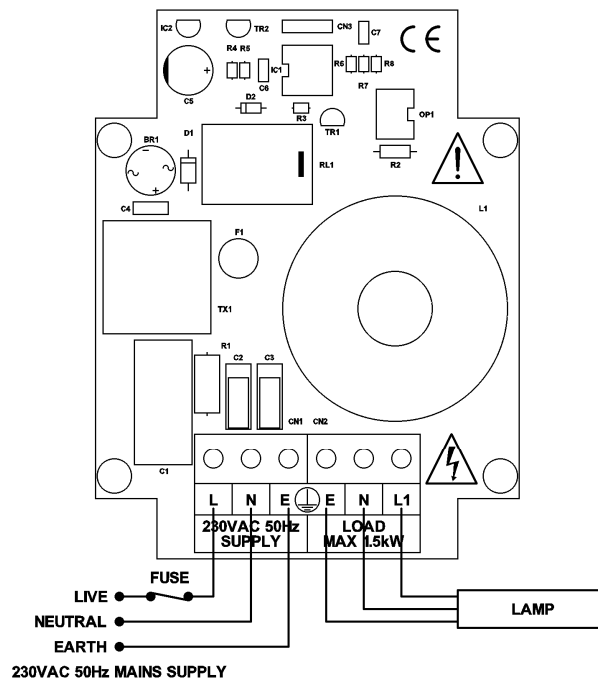

UNITED AUTOMATION LTD

Southport Business Park
 Wight Moss Way
 Southport, PR8 4HQ
 ENGLAND

Tel: 0044 (0) 1704 – 516500
 enquiries@united-automation.com
 www.united-automation.com

unitedautomationltd UA_Limited



8 Safety Advice

It is recommended that installation and maintenance of this equipment should be done with reference to the current edition of the I.E.E. wiring regulations (BS7671) by an approved (NICEIC or equivalent).electrical contractor

These regulations contain important requirements regarding safety of electrical equipment (for International Standards refer to I.E.C/ directive IEC950).

Warning: This device operates at 'Mains Potential'. All installation work and servicing must be performed, with the power supply switched off at source.

9 Installation

Mechanical Fixing: ISOLATE MAINS SUPPLY BEFORE COMMENCING ANY INSTALLATION WORK. Carefully remove the four screws which secure the front panel of the controller, taking care not to damage the ribbon connector anchored to the internal circuit board. The front panel & ribbon connector can be disconnected whilst wall-fixing is carried out and replaced later.

It is recommended that the controller should be mounted securely & vertically on a solid wall with suitable wall-fixings, via the four mounting holes provided.

Warning: Do not drill any additional holes in the enclosure as this will jeopardise the IP-rating of the controller and invalidate warranty.

Avoid locating the controller in areas where it may be subject to exposed to water or direct sunlight.

Ensure that the air-gap is maintained between the wall and the metal heatsink/plate at the rear of the controller to allow adequate cooling of the unit.

Fusing/Protection: The controller must be protected by either a 13A fuse & plug or by suitable remote Fuse/MCB within a distribution panel.

Wiring : DO NOT use more than one single 3-core cable via each cable gland. Use a separate cable for the supply connection and one for the load.

Loosen the cable-glands and feed the cable through - ensure each gland has the internal sealing grommet fitted, to maintain the IP-rating of the enclosure.

Strip back the outer insulation of the 3-core cable to approximately 40mm, making sure the individual cable insulation is not damaged in the process. Leave the Earth cable at approximately 40mm and cut the remaining two cables back to 30mm. Strip each individual cable end back about 6mm, and feed the whole cable through the correct cable gland.

Connect the cables to the correct terminals as marked on the printed circuit board, making sure that the Earth wire is at least 10mm longer than the other wires.

Tighten each cable-gland, making sure that the rubber sealing grommet is tightly gripping the outer insulation of the cables.

The front cover should be replaced ensuring, the ribbon connector is securely fitted and that the seal is seated properly in the groove on the lid.

10 Commissioning

With the cover securely fitted to the unit and the load (lamp) mounted & connected, following the instructions provided, switch on the power to the controller.

The Red 'Status' LED indicator should not be illuminated.

By pressing the '+' button once, the output level should increase to 'Low' and the Red 'Status' LED should now be illuminated. Pressing the '+' button three more times should increase the output to full-power.





Pressing the '-' button will decrease the output levels, one step at a time and the LED should be illuminated if there is power to the load (lamp).



UNITED AUTOMATION LTD

Southport Business Park
Wight Moss Way
Southport, PR8 4HQ
ENGLAND

Tel: 0044 (0) 1704 – 516500
enquiries@united-automation.com
www.united-automation.com

    unitedautomationltd  UA_Limited

